

TOUCH TERMINALS

## HMe Series Instruction Manual



## Table of contents

<b>1. Introduction</b>	<b>3</b>
<b>2. Important symbols</b>	<b>4</b>
<b>3. Product overview</b>	<b>5</b>
<b>4. Standards and approvals</b>	<b>6</b>
<b>5. Product identification</b>	<b>7</b>
<b>6. Technical data common to all models</b>	<b>8</b>
6.1 Hardware specifications	8
6.2 Environmental conditions	8
6.3 Electromagnetic compatibility (EMC)	8
6.4 Durability information	9
6.5 Viewing angles	9
<b>7. Technical data by model</b>	<b>10</b>
<b>8. Product dimensions</b>	<b>11</b>
8.1 HMe04	11
8.2 HMe07	12
8.3 HMe10	13
<b>9. Installation</b>	<b>14</b>
9.1 Installation environment	14
9.2 Installation procedure	15
<b>10. Connections</b>	<b>16</b>
10.1 HMe04	16
10.2 HMe07	17
10.3 HMe10	18
10.4 Serial port	19
10.5 Ethernet port	19
10.6 Power supply, grounding, and shielding	20
<b>11. Cleaning faceplates</b>	<b>21</b>
<b>12. Getting started</b>	<b>21</b>
<b>13. System settings tool</b>	<b>22</b>
13.1 Introduction	22
13.2 Activation of system settings in user mode	22
13.3 Activation of system settings in system mode	23
13.4 Options available in system settings	23
<b>14. Touch screen calibration</b>	<b>24</b>
<b>15. Unpacking and packing instructions</b>	<b>24</b>
<b>16. Record of changes</b>	<b>25</b>

## **1. Introduction**

This instruction manual contains information about the installation, transportation, storage, assembly, use and maintenance of programmable displays of the HMe series.

The following models are available:

- HMe04: Programmable display with TFT color 4.3" widescreen display touch screen
- HMe07: Programmable display with TFT color 7" widescreen display touch screen
- HMe10: Programmable display with TFT color 10.1" widescreen display touch screen

## 2. Important symbols

One or more of the following symbols may be used in this documentation to indicate the type of hazard.

### **DANGER**

Indicates a hazardous situation which, if not avoided, will result in death or serious injury.

### **WARNING**

Indicates a hazardous situation which, if not avoided, could result in death or serious injury.

### **CAUTION**

Indicates a hazardous situation which, if not avoided, could result in serious or moderate injury.

### **Notice**

Indicates a property damage message.

### 3. Product overview

The HMe series programmable displays combine state-of-the-art features and top performance with an outstanding design. They are the ideal choice for all demanding HMI applications including factory and building automation.

The HMe series programmable displays have been designed to run the HMWIN software.

- Compatible with HMWIN Studio.
- Full vector graphic support. Native support of SVG graphic objects, transparency and alpha blending.
- Screen object dynamics: control visibility and transparency, move, resize, rotate any object on screen. Change properties of basic and complex objects.
- Multilanguage applications with TrueType fonts. Easily create, install and maintain applications in multiple languages to meet global requirements.
- Data display in numerical, text, bargraph, analog gauges and graphic image formats.
- Rich set of state-of-the-art HMI features: data acquisition and logging, trend presentation, alarm handling, scheduler and timed actions (daily and weekly schedulers, exception dates), recipes, security and user management, email and RSS feeds.
- Wide selection of communication drivers available with multiple-driver communication capability.
- Remote monitoring and control with client/server functionality.
- On-line and Off-line simulation with HMWIN Studio.
- Powerful scripting language for automated HMI applications. Efficient script debugger improves productivity in application development.
- Rich gallery of vector symbols and objects.

#### **4. Standards and approvals**

The products have been designed for use in an industrial environment in compliance with the 2014/30/ EU EMC Directive.

The products have been designed in compliance with:

EN 61000-6-4	EN 55011 Class A
EN 61000-6-2	EN 61000-4-2
	EN 61000-4-3
	EN 61000-4-4
	EN 61000-4-5
	EN 61000-4-6

The installation of these products into the residential, commercial and light-industrial environments is allowed only in the case that special measures are taken in order to ensure conformity to EN 61000-6-3.

In compliance with the above regulations the products are CE marked.

## **5. Product identification**

The product may be identified through a plate attached to the rear cover. You will have to know the product type you are using for correct usage of the information contained in the guide.

The following information is provided by the plate:

- Product model name
- Product part number
- Year/week of production
- Version ID of the product
- Serial number

## 6. Technical data common to all models

### 6.1 Hardware specifications

<b>Touch screen technology</b>	Resistive
<b>Real-time clock back-up</b>	Supercapacitor
<b>Fuse</b>	Automatic
<b>Serial port</b>	RS232, RS485, RS422 software configurable
<b>Recipe memory</b>	Flash
<b>Real-time clock</b>	Clock/calendar with supercapacitor back-up
<b>Accuracy real-time clock (at 25°C)</b>	<100ppm

### 6.2 Environmental conditions

<b>Operating temperature (surrounding air temperature)</b>	0 to +50°C	EN 60068-2-14
<b>Storage temperature</b>	-20 to +70°C	EN 60068-2-14
<b>Operating and storage humidity</b>	5–85% RH not-condensing	EN 60068-2-30
<b>Vibrations</b>	5–9Hz, 7mm <sup>p-p</sup> 9–150Hz, 1g	EN 60068-2-6
<b>Shock</b>	±50g, 11ms, 3 pulses per axis	EN 60068-2-27
<b>Degree of protection</b>	IP66 front panel (see note)	EN 60529
<b>Pollution degree environment</b>	2	

\* The front face of the unit, installed in a solid panel, has been tested using conditions equivalent to the standards shown in the “Environmental conditions”. Even though the level of resistance unit is equivalent to these standards, oils that should have no effect on the HMe can possibly harm the unit. This can occur in areas where either vaporized oils are present, or where low viscosity cutting oil are allowed to adhere to the unit for long periods of time. If the front face protection sheet on the HMe becomes peeled off, these conditions can lead to the ingress of oil into the unit and separate protection measures are suggested. If the installation gasket is used for a long period of time, or if the unit and its gasket are removed from the panel, the original degree of the protection cannot be guaranteed.

### 6.3 Electromagnetic compatibility (EMC)

<b>Radiated disturbance test</b>	Class A	EN 55011
<b>Electrostatic discharge immunity test</b>	8kV (air electrostatic discharge) 4kV (contact electrostatic discharge)	EN 61000-4-2
<b>Radiated, radio frequency, electromagnetic field immunity test</b>	80MHz–1GHz, 10V/m 1.4–2GHz, 3V/m 2–2.7GHz, 1V/m	EN 61000-4-3
<b>Burst immunity test</b>	±2KV DC power port ±1KV signal line	EN 61000-4-4
<b>Surge immunity test</b>	±0.5KV DC power port (line to earth) ±0.5KV DC power port (line to line) ±1KV signal line (line to earth)	EN 61000-4-5
<b>Immunity to conducted disturbances induced by radio frequency field</b>	0.15–80MHz, 10V	EN 61000-4-6



### 6.4 Durability information

<b>Backlight service life (LED type)</b>	20000 hours or more (Time of continuous operation until the brightness of the backlight reaches 50% of the rated value when the surrounding air temperature is 25°C, see note)
<b>Front foil (without direct exposure to sunlight or UV rays)</b>	10 years if the surrounding air temperature is 25°C
<b>UV resistance</b>	Indoor applications: After 300 hours cycled humidity in QUV accelerated weathering, some yellowing and brittleness may be present.
<b>Solvent resistance</b>	Contact for 1/2 hour at 21°C, no visible effect: acetone, butyl cellosolve, cyclohexanone, ethyl acetate, hexane, isopropyl alcohol, mek, methylene chloride, toluene, xylene Contact for 24 hours at 49°C, no visible effect: coffee, ketchup, lemon juice, mustard (slight yellow stain), tea, tomato juice.
<b>Touch screen reliability</b>	>1 million operations

\* Extended use in environments where the surrounding air temperature is 40°C or higher may degrade backlight quality/reliability/durability.

### 6.5 Viewing angles

The viewing angles for the horizontal (L, R) and vertical (U, D) axes are specified in reference to the vertical axis of the display. The viewing angles always refer to the standard mounting orientation.

For the viewing angle values (U, D ,R ,L), refer to the technical data of the respective touch terminal model.

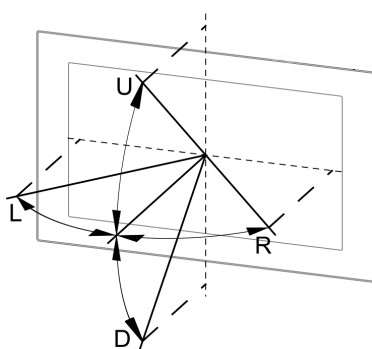

U: From top      D: From bottom  
L: From left     R: From right

## 7. Technical data by model

Model	HMe04	HMe07	HMe10
Display / Backlight	TFT Color / LED		
Colors	64K		
Resolution	480x272	800x480	1024x600
Display size (inch)	4.3 widescreen	7" widescreen	10.1" widescreen
Dimming	yes		
Horizontal viewing angle	L/R: typ. 70°		L: typ. 60°, R: typ. 70°
Vertical viewing angle	U: typ. 70°, D: typ. 50°	U: typ. 50°, D: typ. 70°	U/D: typ. 70°
User memory flash	60MB		
RAM	256MB DDR	512MB DDR	
Serial port	RS232, RS485, RS422 DB9 female software configurable		RS232, RS485, RS422 software configurable
Ethernet port	10/100Mbit		
USB port	Host interface V2.0, max. 500mA		
Real-time clock	yes		
Voltage	24V DC	18–32V DC	
Current rating (at 24V DC)	0.25A	0.30A	0.38A
Weight	0.4kg	0.6kg	1kg

**8. Product dimensions**

**8.1 HMe04**

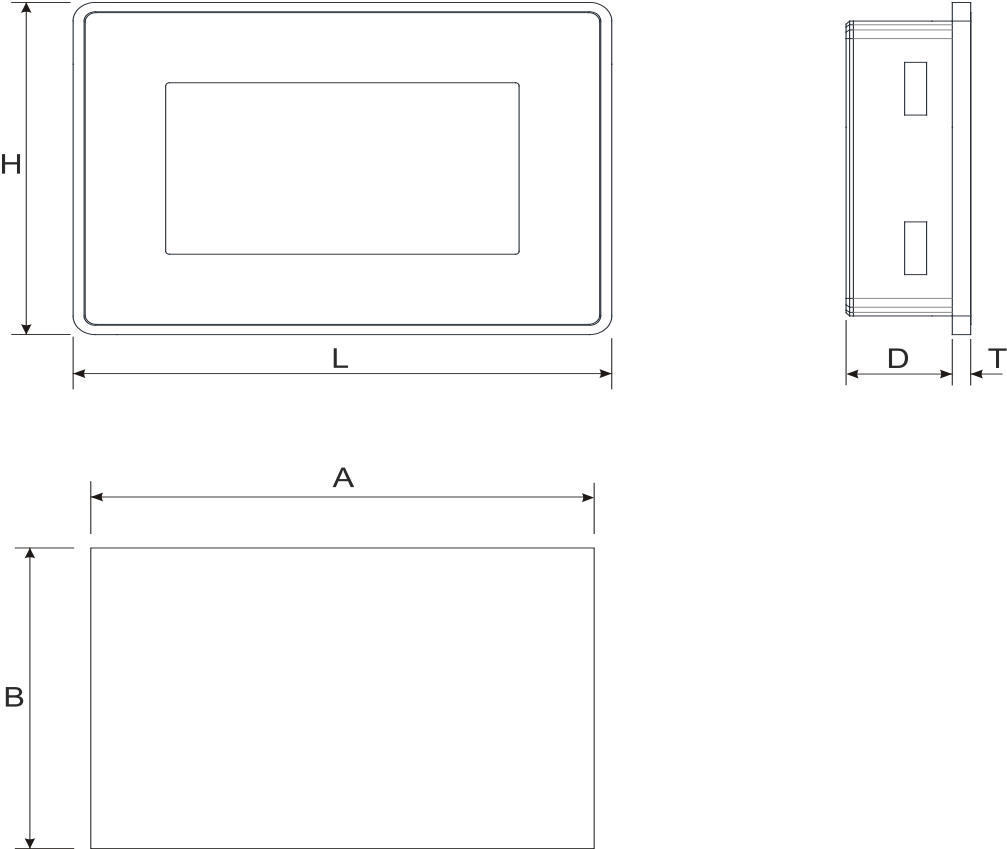

Model	A	B	L	H	D	T
HMe04	136mm	96mm	147mm	107mm	29mm	5mm

8.2 HMe07

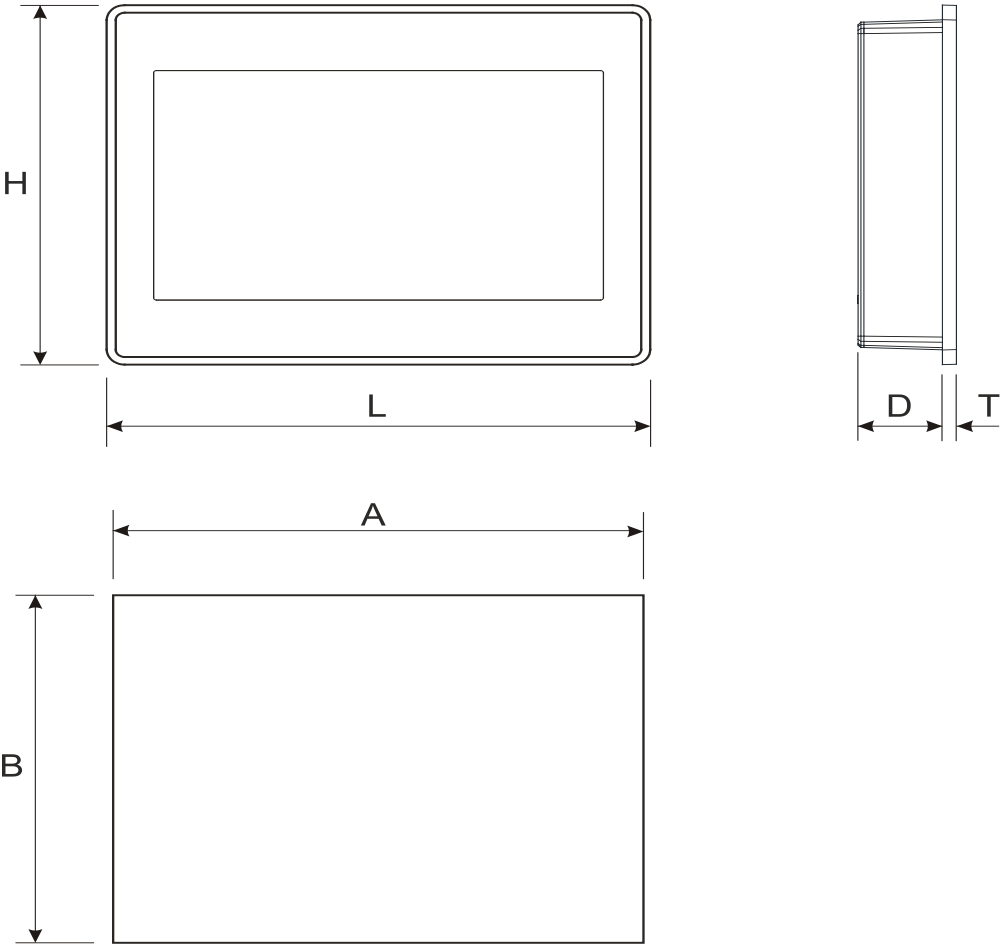

Model	A	B	L	H	D	T
HMe07	176mm	136mm	187mm	147mm	29mm	5mm

8.3 HMe10

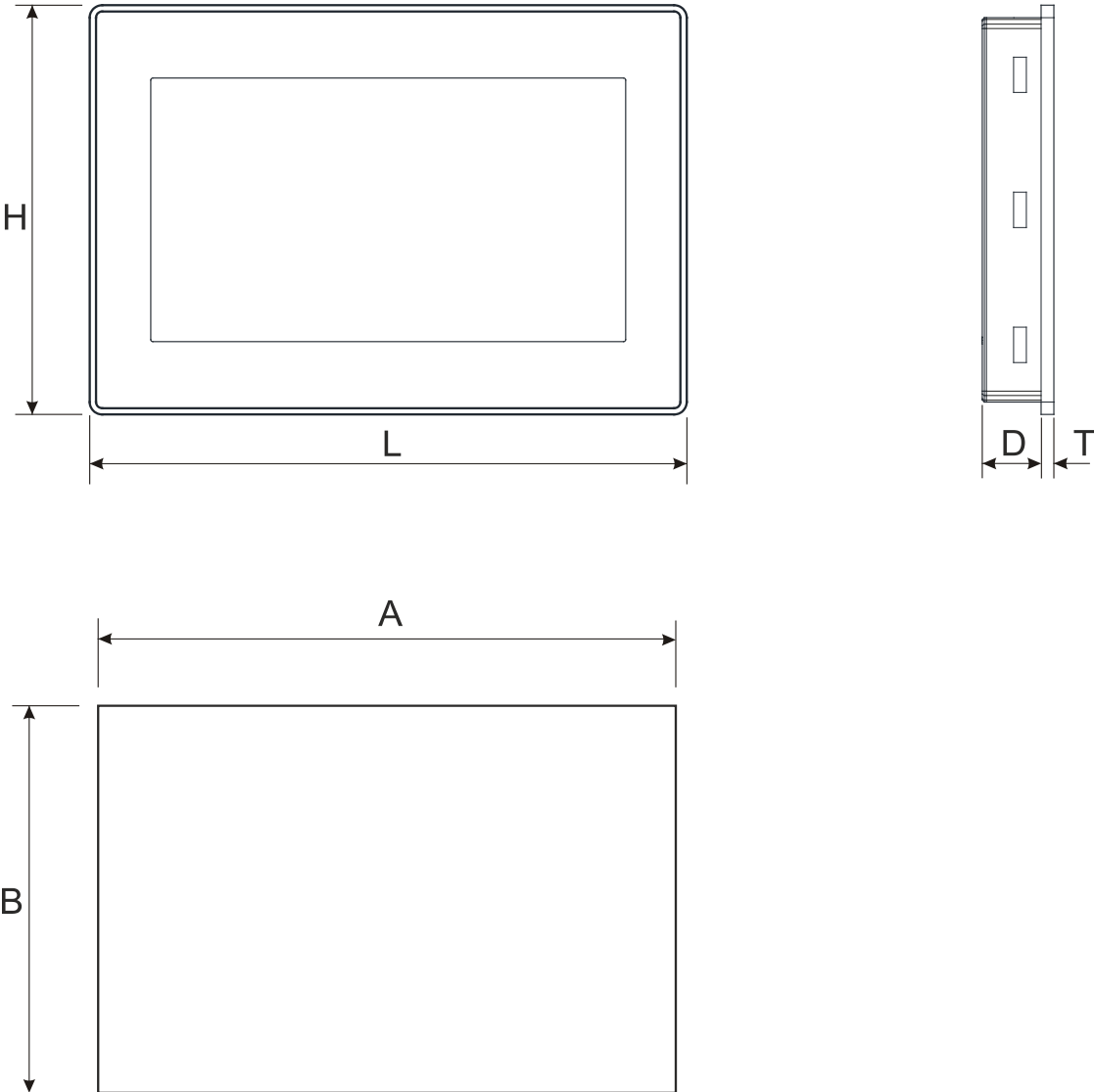

Model	A	B	L	H	D	T
HMe10	271mm	186mm	282mm	197mm	29mm	6mm

## 9. Installation

### 9.1 Installation environment

In order to meet the front panel protection classifications, proper installation procedure must be followed:

- The borders of the cutout must be flat.
- Each fixing screw must be tightened until the plastic bezel corner get in contact with the panel.
- The cutout for the panel must be of the dimensions indicated in this manual.

The product is not intended for continuous exposure to direct sunlight. This might accelerate the aging process of the front panel film.

The product is not intended for installation in contact with corrosive chemical compounds. Check the resistance of the front panel film to a specific compound before installation.

Do not use tools of any kind (screwdrivers, etc.) to operate the touch screen of the product.

The IP66 is guaranteed only if:

- The max. deviation from the plane surface to the cutout is  $\leq 0.5\text{mm}$
- The thickness of the case where the product is mounted is from 1.5mm to 6mm
- The max. surface roughness where the gasket is applied is  $\leq 120\mu\text{m}$ .

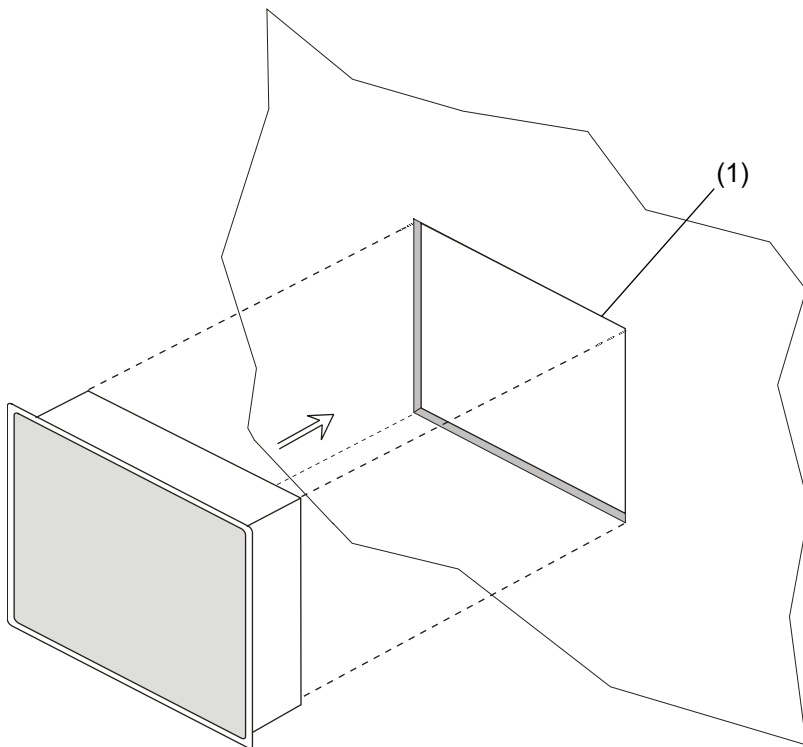

(1) Installation cutout

## 9.2 Installation procedure

For details on installation, please refer to the Installation Guide provided with the product. Place the fixing brackets as shown in the following figure.

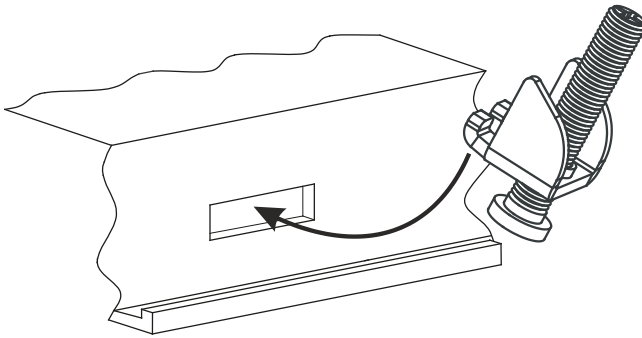

### **!** Notice

Make sure to screw each fixing screw until the bezel corner gets in contact with the panel.

Tightening torque: 75 Ncm

### 10. Connections

#### 10.1 HMe04

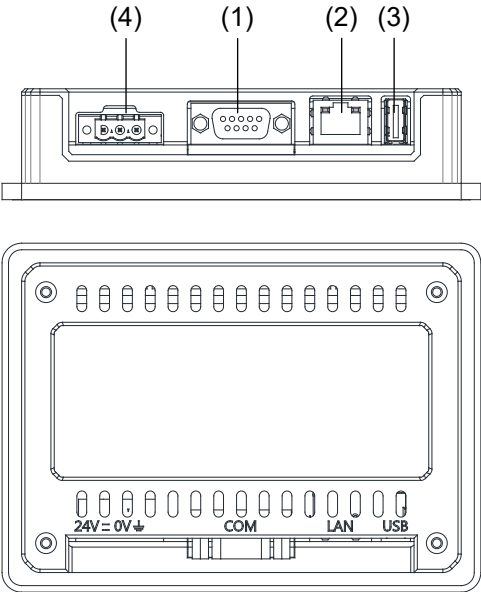

- (1) Serial port
- (2) Ethernet port
- (3) USB port
- (4) Power supply



## 10.2 HMe07

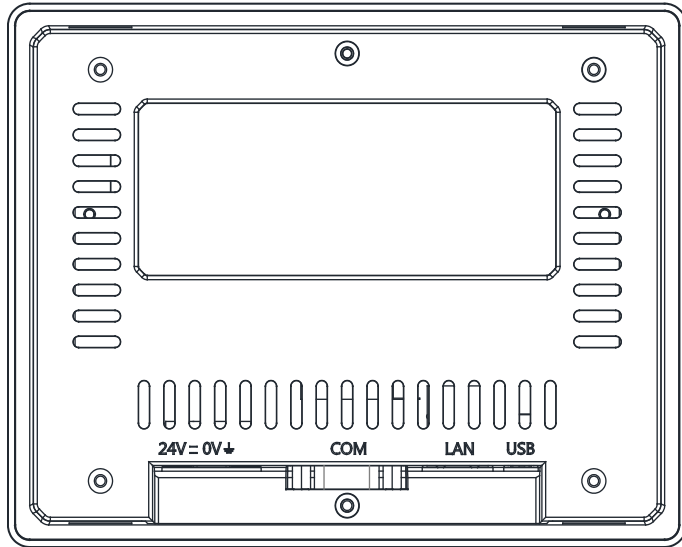
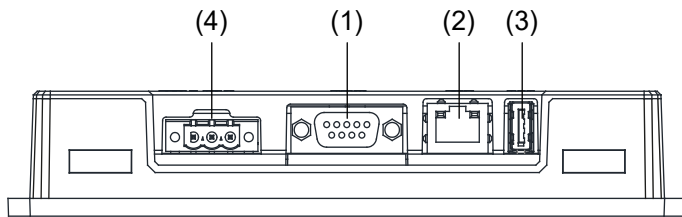

- (1) Serial port
- (2) Ethernet port
- (3) USB port
- (4) Power supply

10.3 HMe10

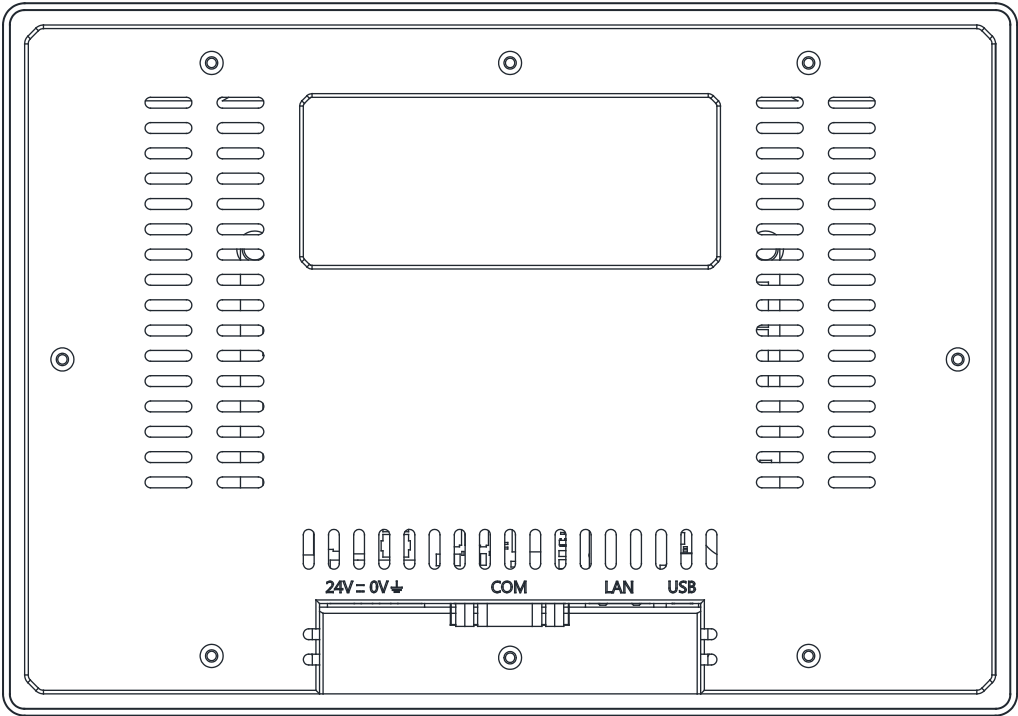
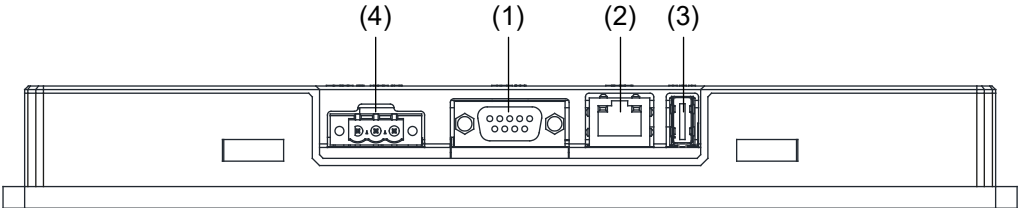

- (1) Serial port
- (2) Ethernet port
- (3) USB port
- (4) Power supply

### 10.4 Serial port

The serial port is used to communicate with the PLC or with another type of controller.

Standards available for the signals in the PLC port connector are: RS232, RS422, RS485. Use the corresponding communication cable for the connection.

The serial port is software programmable. Make sure you select the appropriate interface in the programming software.

#### RS232

Pin	Description
1	GND
2	
3	TX
4	RX
5	
6	+5V output
7	CTS
8	RTS
9	

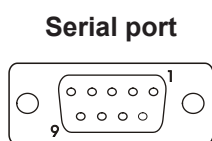

#### RS422, RS485

Pin	Description
1	GND
2	
3	CHA-
4	CHB-
5	
6	+5V output
7	CHB+
8	CHA+
9	

For RS485, pins 4-3 and 8-7 must be connected externally.

### 10.5 Ethernet port

The Ethernet port has two LED status indicators. They work as shown in the following table.

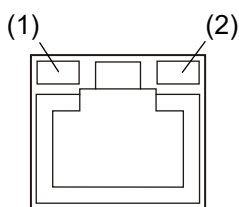

(1) Green LED	(2) Yellow LED	Description
ON	OFF	No LAN cable connected
BLINKING (link active)	ON	LAN cable connected with 100Mbit/s link
BLINKING (link active)	OFF	LAN cable connected with 10Mbit/s link

## 10.6 Power supply, grounding, and shielding

The power supply terminal block is shown in the following figure.

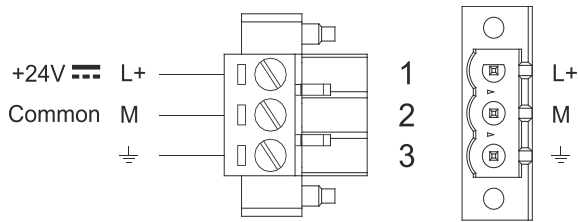

DC power connector - AWG24 wire size - R/C terminal blocks (XCFR2), female pitch 5.08mm, torque 4.5 lb-in

### NOTE

Make sure that the power supply has sufficient power capacity for the operation of the product.

The product must always be grounded to earth. Grounding helps limit the effects of noise due to electromagnetic interference on the control system.

Use terminal 3 on the power supply terminal block earth connection.

The power supply circuit may be floating or grounded. In the latter case, the power source common is connected as indicated with a dashed line in the following figure.

When using the floating power scheme, note that internally the power common is connected to the ground with a  $1M\Omega$  resistor in parallel with a  $4,7nF$  capacitor.

The power supply must have double or reinforced insulation. The suggested wiring for the power supply is shown in the following figure.

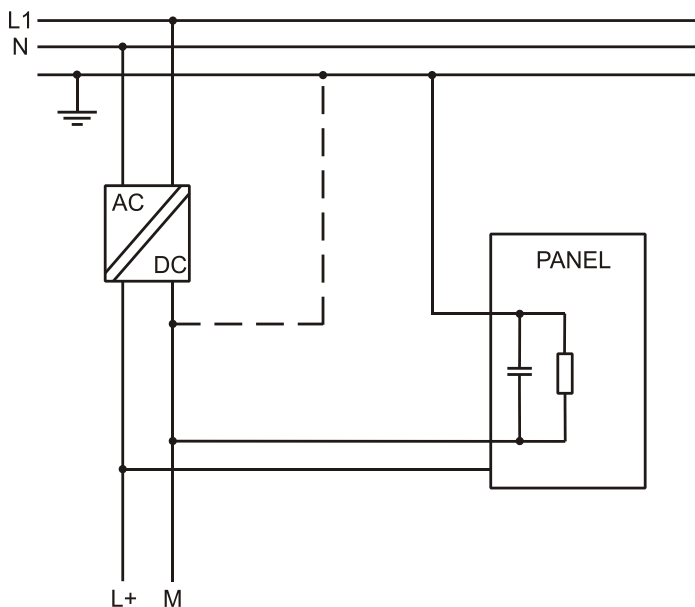

All the electronic devices in the control system must be properly grounded. Grounding must be performed according to applicable regulations.

## 11. Cleaning faceplates

The product must be cleaned only with a soft cloth and neutral soap product. Do not use solvents.

## 12. Getting started

The HMe series panels must be programmed with the programming software HMWIN Studio (starting from v2.6), a Windows application.

There are two options to transfer a HMWIN application project to a panel:

- Ethernet**      Connect the panel via the Ethernet interface to a personal computer running the HMWIN Studio software. Select “Run/Download to target” in HMWIN Studio.  
  
                    Make sure that the firewall policy is configured in a way that allows HMWIN Studio to access the network.
- USB**            Create an update package using the HMWIN Studio software and copy it to an USB flash drive.

## 13. System settings tool

### 13.1 Introduction

The HMe series panels have a system settings interface to allow the configuration of system options.

The user interface of “System Settings” is based on HTML pages accessible locally on HMI or remote using a web browser, e.g. Chrome v44 or higher on port 443 ([https://IP/machine\\_config](https://IP/machine_config)). The default username is “admin”, and the default password is “admin”.

Use the navigation menu on the left side of the screen to browse through the available options.

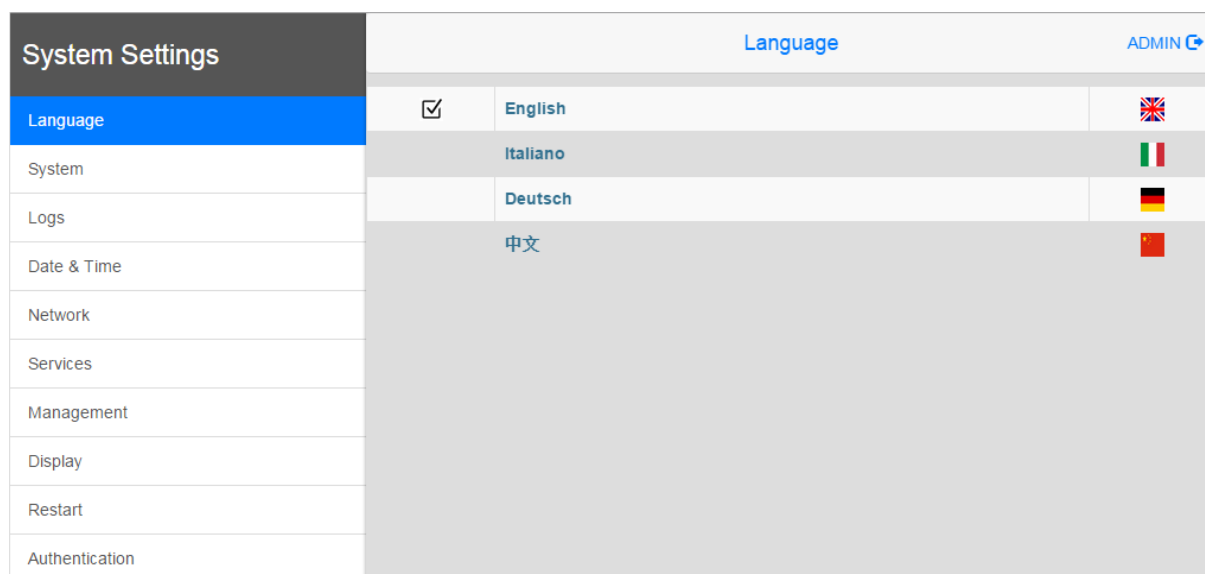

On the left side, the selected menu item is highlighted. The right side shows related information and settings. Based on the size of the panel, menu and content of the selected menu item may not be displayed next to each other on the screen.

The system settings interface has two operating modes:

**User mode** HMWIN runtime is running or the status of the HMI panel is set to “factory default”.

**System mode** HMWIN runtime is not running or there is a software failure.  
The system mode includes all options available in user mode. In addition, the system mode offers commands dedicated to system upgrade and recovery which are not available in user mode.

### 13.2 Activation of system settings in user mode

**HMWIN runtime not running** Touch the “System Setting” button on the HMI panel.

**HMWIN runtime running** To activate the system settings in user mode, touch and hold any unused area of the touch screen for a few seconds to access the context menu. The default holding time is 2 seconds.

### 13.3 Activation of system settings in system mode

<b>Normal operation</b>	<p>If HMWIN runtime is not running: Touch the “System Setting” button on the HMI panel to open the system settings in user mode. Select “Restart” &gt; “Config OS” to reboot in system mode.</p> <p>If HMWIN runtime is running: To activate the system settings in user mode, touch and hold any unused area of the touch screen for a few seconds to access the context menu. The default holding time is 2 seconds. Select “Restart” &gt; “Config OS” to reboot in system mode.</p>
<b>Recovery operation</b>	<p>If the HMI panel is not responsive, tap on the surface of the touch screen during the power-up phase of the panel. The tapping frequency must be high. Start tapping the touch screen as soon as power has been supplied to the panel. The message “TAP-TAP DETECTED” appears when the operating sequence has been recognized. Release the touch screen to boot in user mode without running HMWIN runtime or touch and hold the touch screen for a few seconds. Then select “Restart” &gt; “Config OS” to boot in system mode.</p>

### 13.4 Options available in system settings

The following important basic setting options of the panel are available:

<b>Language</b>	Configure the language used for the system setting menu only.
<b>System</b>	Shows information about platform, status and timers (e.g. system on time, backlight on time).
<b>Logs</b>	Enable persistent log for BSP and allows to export it.
<b>Date &amp; Time</b>	Change the date and time of the panel, including time zone and NTP server.
<b>Network</b>	Configure the IP address of the Ethernet interface and the other network settings, e.g. DNS, gateway, DHCP, hostname.
<b>Services</b>	Enable/disable services, e.g. OpenSSH server, cloud services, SNMP and logging.
<b>Management</b>	Update BSP components (Main OS, Config OS, Boot loader, XLoader), check partition consistency, update the splash screen, show the usage and size of partitions. The update of “Main OS” is only available in system mode. The update of “Config OS” is only available in user mode.
<b>Display</b>	Adjust the brightness, configure automatic backlight turnoff and select HMI orientation (90°, 180°, 270° and 360°).
<b>Restart</b>	Restart the panel. Select “Main OS” to restart the panel in user mode (default setting). Select “Config OS” to restart the panel in system mode and open the system settings.
<b>Authentication</b>	Configure the administrator (“admin”) and the standard user (“user”) password. An administrator has full access to the “System Settings” (e.g. BSP updates and other system components). A standard user has some limitations.

#### NOTE

The system settings tool includes also other options that are not described and not documented in this manual. For details, please refer to the HMWIN User Manual.

## 14. Touch screen calibration

The HMe series panels support the calibration of the interface. To start calibration do the following:

- Tap on the surface of the touch screen during the power-up phase of the panel. The tapping frequency must be high. Start tapping the touch screen as soon as power has been supplied to the panel. The message “TAP-TAP DETECTED” appears when the operating sequence has been recognized.
- Release the touch screen and wait a few seconds until the message “ENTERING SYSTEM SETTINGS” appears.
- Touch and hold the touch screen for a few seconds to select “TOUCHSCREEN CALIBRATION”.

## 15. Unpacking and packing instructions

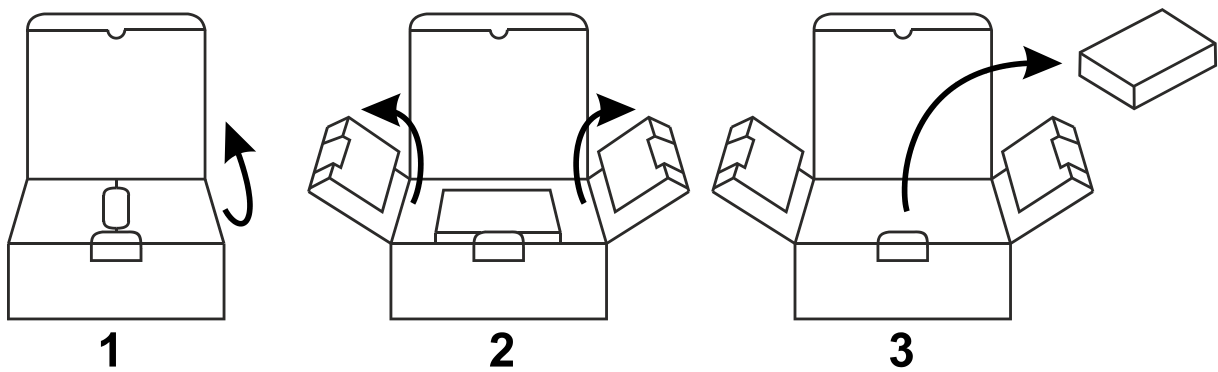

To repack the product, please follow the instructions backwards.



**16. Record of changes**

<b>Manual No.</b>	<b>Date</b>	<b>Description of changes</b>
ACGM0195V1EN	September 2017	First edition based on the eSMART Series Operating Instructions version 1.01
ACGM0195V2EN	June 2018	Second edition <ul style="list-style-type: none"><li>• Added the model HMe04</li><li>• Updated the phone number of the Polish office and deleted the fax number on the back page</li></ul>
ACGM0195V3EN	February 2019	Third edition <ul style="list-style-type: none"><li>• Removed the pictures of the rating plates</li><li>• Added "Important symbols" page</li></ul>
ACGM0195V4EN	April 2021	Fourth edition <ul style="list-style-type: none"><li>• Added information about the viewing angles of the displays</li><li>• Updated website URL</li><li>• Updated back page</li></ul>

Distributed by Panasonic Electric Works Europe AG

<https://industry.panasonic.eu/>

Subject to change without notice.

The information contained in this document is provided for informational purposes only. While efforts were made to verify the accuracy of the information contained in this documentation, it is provided "as is" without warranty of any kind.

Third-party brands and names are the property of their respective owners.



North America

Europe

Asia Pacific

China

Japan

## Panasonic Electric Works

Please contact our Global Sales Companies in:

### Europe

▶ <b>Headquarters</b>	<b>Panasonic Electric Works Europe AG</b>	Caroline-Herschel-Strasse 100, 85521 Ottobrunn, Tel. +49 89 45354-1000, Fax +49 89 45354-1550, <a href="http://www.panasonic-electric-works.com">www.panasonic-electric-works.com</a>
▶ <b>Austria</b>	<b>Panasonic Industry Austria GmbH</b>	Josef Madersperger Str. 2, 2362 Biedermannsdorf, Tel. +43 (0) 2236-26846, Fax +43 (0) 2236-46133 <a href="http://www.panasonic-electric-works.at">www.panasonic-electric-works.at</a>
	<b>Panasonic Industrial Devices Materials Europe GmbH</b>	Ennshafenstraße 30, 4470 Enns, Tel. +43 (0) 7223 883, Fax +43 (0) 7223 88333, <a href="http://www.panasonic-electronic-materials.com">www.panasonic-electronic-materials.com</a>
▶ <b>Benelux</b>	<b>Panasonic Electric Works Sales Western Europe B.V.</b>	De Rijn 4, 5684 PJ Best, Netherlands, Tel. +31 (0) 499 372727, <a href="http://www.panasonic-electric-works.nl">www.panasonic-electric-works.nl</a>
▶ <b>Czech Republic</b>	<b>Panasonic Electric Works Europe AG, organizační složka</b>	Administrative centre PLATINIUM, Veveří 3163/111, 616 00 Brno, Tel. +420 541 217 001, Fax +420 541 217 101, <a href="http://www.panasonic-electric-works.cz">www.panasonic-electric-works.cz</a>
▶ <b>France</b>	<b>Panasonic Electric Works Sales Western Europe B.V.</b>	Succursale française, 10, rue des petits ruisseaux, 91370 Verrières Le Buisson, Tél. +33 (0) 1 6013 5757, Fax +33 (0) 1 6013 5758, <a href="http://www.panasonic-electric-works.fr">www.panasonic-electric-works.fr</a>
▶ <b>Germany</b>	<b>Panasonic Electric Works Europe AG</b>	Caroline-Herschel-Strasse 100, 85521 Ottobrunn, Tel. +49 89 45354-1000, Fax +49 89 45354-2111, <a href="http://www.panasonic-electric-works.de">www.panasonic-electric-works.de</a>
▶ <b>Hungary</b>	<b>Panasonic Electric Works Europe AG</b>	Magyarországi Fióktelepe, 1117 Budapest, Alíz utca 4, Tel. +43 (0) 2236 26846 -25, Fax +43 (0) 2236 46133 <a href="http://www.panasonic-electric-works.hu">www.panasonic-electric-works.hu</a>
▶ <b>Ireland</b>	<b>Panasonic Electric Works UK Ltd.</b>	Irish Branch Office, Dublin, Tel. +353 (0) 14600969, Fax +353 (0) 14601131, <a href="http://www.panasonic-electric-works.co.uk">www.panasonic-electric-works.co.uk</a>
▶ <b>Italy</b>	<b>Panasonic Industry Italia srl</b>	Via del Commercio 3-5 (Z.I. Ferlina), 37012 Bussolengo (VR), Tel. +39 0456752711, Fax +39 0456700444, <a href="http://www.panasonic-electric-works.it">www.panasonic-electric-works.it</a>
▶ <b>Nordic Countries</b>	<b>Panasonic Electric Works Europe AG</b>	Filial Nordic, Knarrarnäsgatan 15, 164 40 Kista, Sweden, Tel. +46 859476680, Fax +46 859476690, <a href="http://www.panasonic-electric-works.se">www.panasonic-electric-works.se</a>
	<b>Panasonic Fire &amp; Security Europe AB</b>	Jungmansgatan 12, 21119 Malmö, Tel. +46 40 697 7000, Fax +46 40 697 7099, <a href="http://www.panasonic-fire-security.com">www.panasonic-fire-security.com</a>
▶ <b>Poland</b>	<b>Panasonic Industry Poland sp. z o.o.</b>	Ul. Dowborczyków 25, 90-019 Łódź, Polska, Tel. +48 42 2309633, <a href="http://www.panasonic-electric-works.pl">www.panasonic-electric-works.pl</a>
▶ <b>Spain</b>	<b>Panasonic Industry Iberia S.A.</b>	Barajas Park, San Severo 20, 28042 Madrid, Tel. +34 913293875, Fax +34 913292976, <a href="http://www.panasonic-electric-works.es">www.panasonic-electric-works.es</a>
▶ <b>Switzerland</b>	<b>Panasonic Industry Switzerland AG</b>	Grundstrasse 8, 6343 Rotkreuz, Tel. +41 (0) 41 7997050, Fax +41 (0) 41 7997055, <a href="http://www.panasonic-electric-works.ch">www.panasonic-electric-works.ch</a>
▶ <b>United Kingdom</b>	<b>Panasonic Electric Works UK Ltd.</b>	Sunrise Parkway, Linford Wood, Milton Keynes, MK14 6LF, Tel. +44 (0) 1908 231555, Fax +44 (0) 1908 231599, <a href="http://www.panasonic-electric-works.co.uk">www.panasonic-electric-works.co.uk</a>

### North & South America

▶ <b>USA</b>	<b>Panasonic Industrial Devices Sales Company of America</b>	Two Riverfront Plaza, 7th Floor, Newark, NJ 07102-5490, Tel. 1-8003-442-112, <a href="http://www.pewa.panasonic.com">www.pewa.panasonic.com</a>
--------------	--	---

### Asia Pacific/China/Japan

▶ <b>China</b>	<b>Panasonic Electric Works Sales (China) Co. Ltd.</b>	Tower C 3rd Floor, Office Park, NO.5 Jinghua South Street, Chaoyang District, Beijing 100020, Tel. +86-10-5925-5988, Fax +86-10-5925-5980
▶ <b>Hong Kong</b>	<b>Panasonic Industrial Devices Sales (HK) Co., Ltd.</b>	Suite 301, 3/F, Chinachem Golden Plaza, 77 Mody Road, TST East, Kowloon, Hong Kong, Tel. +852-2529-3956, Fax +852-2528-6991
▶ <b>Japan</b>	<b>Panasonic Corporation</b>	1006, Oaza Kadoma, Kadoma-shi, Osaka 571-8501, Japan, Tel. +81-6-6908-1121, <a href="http://www.panasonic.net">www.panasonic.net</a>
▶ <b>Singapore</b>	<b>Panasonic Industrial Devices Automation Controls Sales Asia Pacific</b>	No.3 Bedok South Road, Singapore 469269, Tel. +65-6299-9181, Fax +65-6390-3953