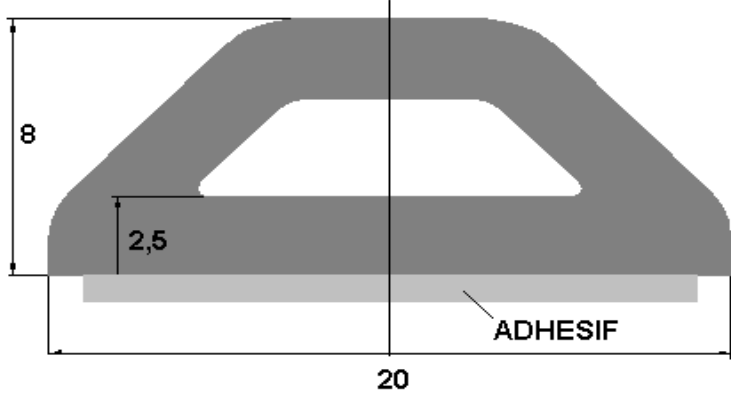
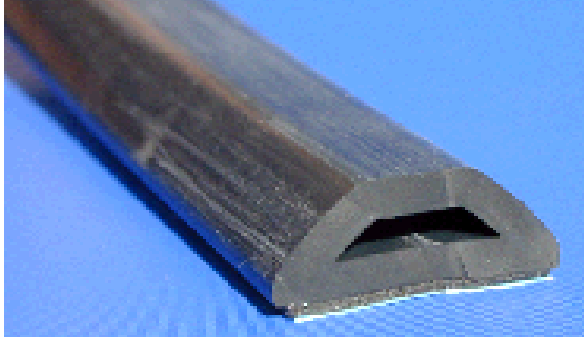

	<p><b>PRODUCT NAME</b> <b>AC20</b></p> <p><b>ITEM NUMBER</b> <b>9F688</b></p>	
<p><b>PRODUCT PICTURE</b></p> 		<p><b>SCALE 1:1</b></p> 

**PRODUCT DESCRIPTION**

**Shockproof protections with adhesive for flat surfaces**

<b>MATERIAL</b>	Grade : Black EPDM
	Hardness : 70 Shores A

<b>MAXIMAL TEMPERATURES OF USE OF THE PROFILE (°C)</b>		
<i>Nonstop static</i>	<i>Nonstop under constraints</i>	<i>Hottest (max duration 30 min)</i>
80	70	110

<b>ADHESIVE</b>		
<i>Peeling Behaviour at 90°</i>	<i>Pull out Behaviour</i>	<i>Temperature of use</i>
10 N/cm minimum	40 N/cm <sup>2</sup>	from -30°C to +90°C

For all inquiries feel free to contact : HUTCHINSON - Le Pommarin - BP 17 - 38430 MOIRANS  
 Tel. +33 4 76 35 79 00 - Fax +33 4 76 35 79 09

